

Effectiveness of the Polymer Electrolyte Membrane Fuel Cell in High Humidity Climate

Z. Jalauddin, N. M. Nor, T. Ibrahim, and Y. T. Sin

Electrical and Electronic Engineering Department,

Universiti Teknologi PETRONAS

Bandar Seri Iskandar, 31720 Tronoh, Perak, Malaysia

Tel: +605 368 7814, fax: +605 364 7443

E-mail: taibib@petronas.com.my, nursyarizal_mnor@petronas.com.my

Received: 29 September 2012 / Accepted: 29 October 2012 / Published: 18 December 2012

Abstract: The hydrogen gas can be used as an alternative energy to replace the fossil fuel to generate the electricity. The hydrogen gas produced will be used to generate electricity by using the Polymer Exchange Membrane Fuel Cell (PEMFC). A green innovation model to produce the hydrogen gas from the electrolysis process by using a solar panel and electrolyzer is presented in this paper. This project is green friendly and can save the world from the pollution because there is no emission of the greenhouse gas such as CO₂. The results obtained from the several test conducted had shown that air pressure and humidity effect in the high humidity climate are the parameters would found to have the significant effect to the performance of PEMFC. The experimental results are analyzed to prove effectiveness of the system. Prototype model using the solar electrolyzer and PEMFC is applied to the hybrid car and air pump for fish pond. *Copyright © 2012 IFSA.*

Keywords: Hydrogen gas, Solar panel, Electrolyzer, PEMFC, Efficiency.

1. Introduction

Many manufacturers produce new vehicles, electrical and electronic appliances to make human life easier. All of these products depend to the fossil fuel and electricity as a source of energy. This will increase the emission of the green house gas which is very dangerous for living things especially to the environment. Therefore, new approach is required to improve alternative energy in order to replace the current energy source in order to save our world.

Nowadays, a lot of alternative energies have been produced to reduce the usage of the fossil gas but only minority of people are fully utilized this alternative energy. Even though the alternative energy maybe expensive compared to the current source of energy but it make the environment safe and clean. By improvising the available fuel cell by adding special features and design, it will encourage people to use it since it only use water as a source of hydrogen and oxygen gas to produce electricity. Thus, this can be the best alternative to produce clean energy without affecting the environment.

For this new innovation it can be used as a power supply and also the backup supply in critical case at the same time. This innovation focuses to those who require continuous power supply. The application of power supply produced by this innovation can be used to the solar hybrid car and air pump for the fish pond application and also for the electronic appliances such as mobile phone. This is the first portable power supply that has two backup supplies which are hydrogen gas and the ultra capacitor. Thus, this green innovation is absolutely clean with no emission of the greenhouse gas and become one of the efficient alternative energy.

2. Polymer Electrolyte Membrane Fuel Cell

Polymer Electrolyte Membrane Fuel Cell (PEMFC) is also known as Proton Exchange Membrane Fuel Cell. In particular, among the available fuel cells, PEMFC fuel cells offer excellent features, such as compact structure, high power density, solid electrolyte, low-operating temperature (50 °C–100 °C), relatively fast start-up, low sensitivity to orientation, favourable power-to-weight ratio, long cell and stack life and low corrosion [1, 2].

As one of the type of fuel cells, it produces electricity energy from the chemical reaction of the hydrogen gas in the cell. The structure of PEMFC is similar to the other fuel cells which have two electrodes coated with the platinum catalyst separated by a polymer electrolyte membrane (PEM) in the middle. The combination of the electrodes and the PEM is called as membrane electrode assembly (MEA).

The function of platinum catalyst is to split the hydrogen gas molecule into hydrogen ions and electrons. It is very stable and will not easily oxidize as compared to the other noble metals such as nickel and silver. The output power of the PEMFC that uses the platinum catalyst is high due to its stability from oxidized. The chemical reaction that will occur at the anode and cathode electrode can be represented in the half reactions:

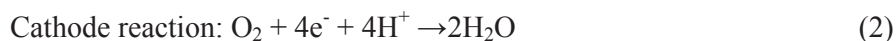
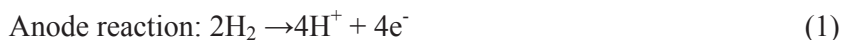

At the anode, the hydrogen molecule is split into the hydrogen ions and electrons. The PEM will allow the hydrogen ions to flow from the anode to the cathode while the electron will flow through the external wire to produce electrical power. The hydrogen ions will combine with the oxygen gas and the electrons at the cathode to produce water. The PEM only allows the hydrogen ion, H⁺ to pass through it while preventing the electron conduction. It is made from the Nafion because of the effectiveness as a membrane. Nafion polymer has excellent chemical stability while at the same time allowing ion transport [3]. The process to split the hydrogen molecule is exothermic which produce heat. So, there is a limitation to the membrane performance because for Nafion the operating temperature is only from 50 °C -120 °C [1, 4].

3. PEMFC Solar Electrolyzer

Solar Electrolyzer is the device that performs the electrolysis process to produce hydrogen and oxygen gas from the water which is also known as hydrolysis process. The function of PEMFC is not only produce electrical power but it also can be used to perform hydrolysis process to produce hydrogen gas. This device is called reversible PEMFC where it can produce hydrogen gas and generate electricity at the same device. By using a direct current (DC) supply to the anode and cathode, the hydrolysis of water can be done. We can use any DC supply such as battery and solar panel but to ensure no pollution occur it is better to use a solar panel as a supply. The chemical reaction which occurs during the hydrolysis process:



According to the Fig. 1, the water molecule is split into positive hydrogen ion, H^+ and negative hydroxide ion, OH^- :



The electrodes polarity is different from the PEMFC because the supply is given to the electrodes. At the cathode the negative electrode, the electrons are pushed into the water and the hydrogen ion will attract to it to form hydrogen molecule. The combination of the two hydrogen molecules will produce hydrogen gas.

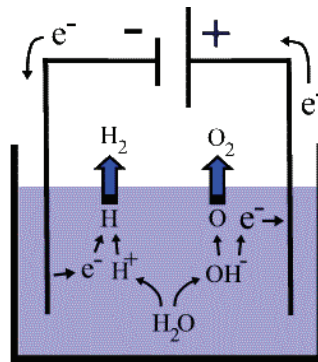
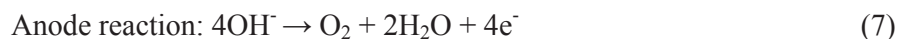

Fig. 1. Hydrolysis of water [5].



At the anode the positive electrode, the extra electrons from the hydroxide ion are absorbed. The combination of four hydroxide molecules will produce oxygen gas and water.



The hydrogen and oxygen gas produced will be stored into the storage tank so that it can be used by PEMFC to generate electrical power.

4. PEMFC Stack Efficiency

PEMFC produces electrical energy from the flow of the hydrogen gas through the MEA. The electrons produced from the chemical reaction will generate the current and voltage. By using only one stack of PEMFC, the voltage produced is very small. Thus, to achieve a higher voltage, many stack cells need to be connected in series just like battery series connection.

At zero current the voltage is the highest which is the open circuit voltage. Usually at the standard condition, the value for the hydrogen-oxygen couple is 1.23 V but under practical conditions the open-circuit potential will settle at values slightly below 1 V. To achieve a high output power of fuel cell stack, it should be operated at high current densities.

However, the current cannot be increased at will, as the power output will reach a maximum due to the voltage drop. After this maximum the power output will decrease with increasing current. Fig. 2 shows the characteristics of the performance of PEMFC. The maximum power of a PEMFC stack is highly dependent on the operating parameters [6].

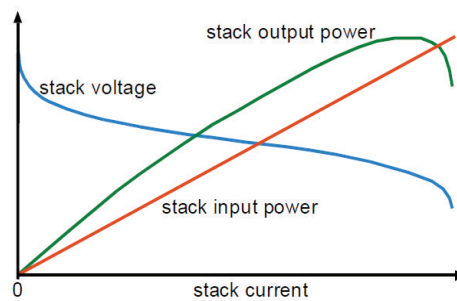

Fig. 2. Stack voltage with input and output power [7].

The efficiency of a PEMFC can be defined as:

$$\eta = \frac{P_{OUT}}{P_{IN}} \quad (8)$$

$$\eta = \frac{V_{stack} \times I_{stack}}{I_{stack} \times N_C \times 1.481}, \quad (9)$$

where

V_{stack} = Stack voltage;
 I_{stack} = Stack current;
 N_C = Number of stack.

From the (9), the efficiency can be simplified as in (10) [7].

$$\eta = \frac{V_{stack}}{N_C \times 1.481} \quad (10)$$

There are many operating parameters that affect the performance and efficiency of PEMFC but the most critical parameters are *Pressure feed air* and *Humidity of air*.

4.1. Pressure Feed Air

Air is provided to the fuel cell cathode at low pressure by a blower or at high pressure by an air compressor. When the pressure feed gas is high thereby the cell operating pressure is high too. Higher cell operating pressure results in more even distribution of the local current density due to the high oxygen concentration at the catalyst layer [8]. Increasing the pressure of the air improves the kinetics of the electrochemical reactions and leads to higher power density and higher stack efficiency [1]. However, a higher air flow rate means a higher power consumption of the air compressor, which influences the net power available [9]. Thus, the required pressure need to be determined in order to optimizes the overall PEMFC performance for each current density.

4.2. Humidity of Air

Humidification of PEMFC is needed to prevent the electrolyte from drying out [10]. From the fuel cell reaction, the water will exist but it must be removed from the exhaust gas, stored, and pumped to a pressure suitable for the various operations [1]. A low air flow rate increases the humidity of the membrane, which decreases the electrical resistance and improves the performance of the fuel cell, while a high air flow rate increases the rate of water removal that causes drying of the membrane which increases the electrical resistance. However, a high air flow rate increases the availability of oxygen at the cathode membrane which improves the performance of the fuel cell [11, 12]. With the high humidity, the efficiency of the PEMFC decreases possibly due to the fuel cell beginning to flood and the quantity of oxygen gas available in the cell also decreases [10].

5. Prototype Fabrication

5.1. Construction of the Solar Electrolyzer and Hydrogen Gas Storage

This project uses the reversible PEMFC as the electrolyzer to produce the hydrogen gas from the electrolysis process. The components that needed to construct the electrolyzer are the solar panel, reversible PEMFC, tube distilled water, syringe and gas storage cylinders. Fig. 3 shows the complete assembly of PEMFC electrolyzer.

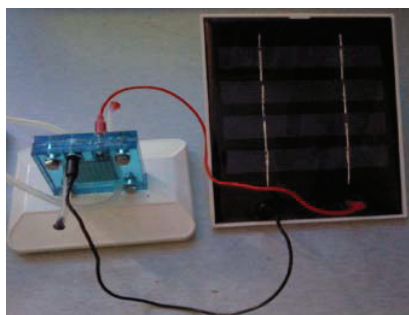

Fig. 3. Solar electrolyzer.

In this project the storage cylinders is designed to have 15 cm height and 21.5 cm diameter which can store 500 mL at 1 bar hydrogen gas. The design of the tank is done using the Computer Aided Design (CAD) drawing as shown in Fig. 4 and Fig. 5 show the storage tanks that have been constructed. Both of the hydrogen and oxygen gas in the storage tanks will be used in the PEMFC to generate electricity.

The bigger the size of the cylinder the higher amount of hydrogen and oxygen gas can be stored. So, more electrical power can be produced for a long period.

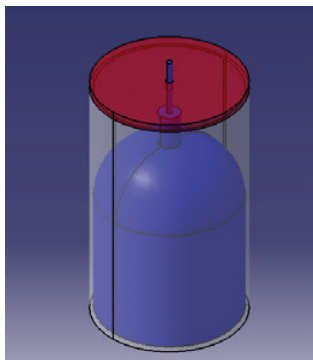

Fig. 4. CAD design of storage tank.



Fig. 5. Fabricated storage tank.

5.2. Construction of the Portable Power Supply PEMFC

The PEMFC cannot operate without other main components such as gas storage tank, tube, cooling fan and wiring cable. All of these components were assembled together to produce electrical energy. For the PEMFC unit construction, the combination of PEM, electrodes and platinum catalyst will form a stack of cells which is called Membrane Electrode Assembly (MEA). In this project, the open cathode PEMFC is used with four stack cells which are combined together in series to produce the desired output 3.6 V, 10 W. The design surface area is 21.5 cm × 7 cm and the total thickness of MEA is 2 cm.

There will be a fitting hole at the anode electrode for the hydrogen gas inlet. The tube is connected to the fitting of the inlet to allow the flow of the hydrogen and from the storage tank to the PEMFC. For the output connection, two plates with 0.2 cm × 3.5 cm surface area of anode and cathode electrode will be connected with two wires for the positive and negative terminal. Fig. 6 shows the CAD design of the PEMFC with the storage tank and terminal anode and cathode connectors.

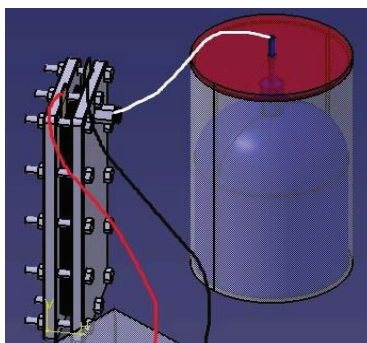

Fig. 6. CAD design of PEMFC with storage tank.

A cooling fan is used to reduce the temperature of the PEMFC and also used to remove the water, and feed the oxygen gas to the cell. The size of cooling fan depends on the size of the PEMFC. In this project, two units of 12 V, 1.0 A cooling fans are used which will be installed at the side of the fuel cell.

The fabrication of the PEMFC unit is done by the G-Energy Technologies Sdn. Bhd. according to the specification design. Fig. 7 shows the complete design of PEMFC after the fabrication process. So, the design of this fuel cell is complete and ready to be used to generate electricity.

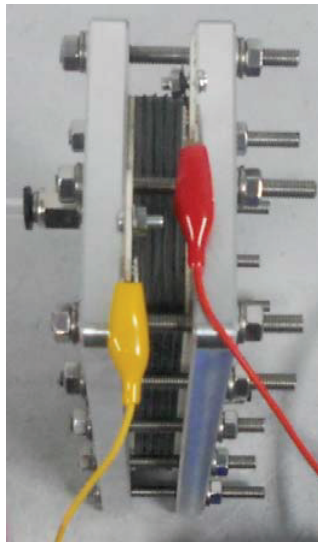

Fig. 7. PEMFC unit.

5.3. Assembly of Prototype Model

This prototype can be used for air pump for the fish pond and motor with controller circuit for the solar hybrid car. The solar electrolyzer with PEMFC that had been fabricated can produce about 3.6 V with 10 W output power which is suitable for the applications of the air pump and small motor since it can produce high current and output power. Boost converter is used to step up the voltage to 5 V to increase the performance of motor. For the air pump it can be used directly the output of PEMFC without any additional circuit because the rating is approximately same as the rating of PEMFC. The air pump is successfully operated to produce maximum oxygen gas to the aquatic life as shown in Fig. 8.

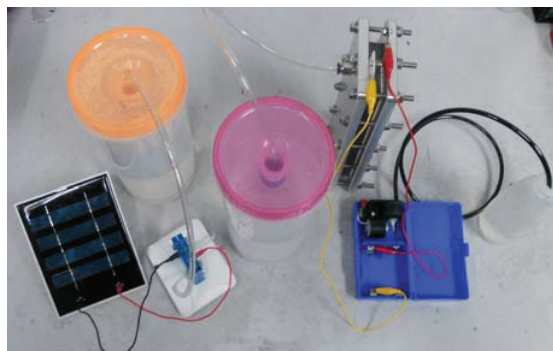

Fig. 8. Air pump application.

This project also is applied to a DC motor with the controller circuit to symbolize the motor for the solar hybrid car. Since the solar hybrid car already has the solar panel, this innovation takes the

opportunity to utilize the solar power to power up the electrolyzer to produce the hydrogen gas. The controller circuit of the motor is designed to be located at the middle of the car as shown in the CAD drawing in Fig. 9.

The booster is used to boost the voltage of PEMFC to 5 V to improve the performance of the motor. As an additional feature, the ultra capacitor circuit also is designed as a backup supply if the hydrogen gas is empty. For the safety purposes, the storage tank of the hydrogen gas is located at the back of the car because the hydrogen gas can easily explode if there is spark or fire. Fig. 10 shows the complete model of the motor for the solar hybrid car. The performance of this innovation depends on the climate of the surroundings such as humidity and quantity of air feed into the PEMFC. This innovation have no limitation, it can be used anywhere and anytime since it have source of sun radiation to produce the hydrogen gas using electrolyzer.

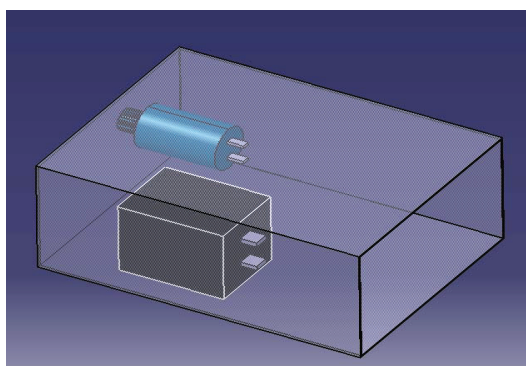

Fig. 9. CAD design motor circuits.

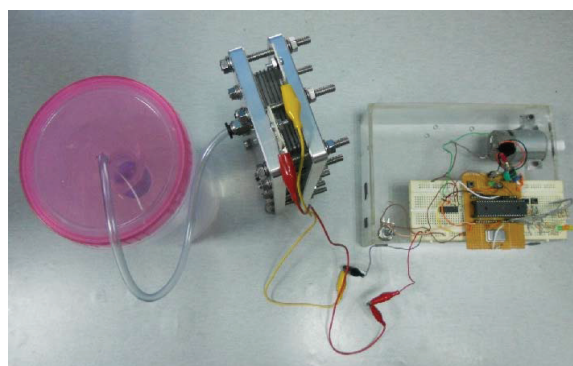

Fig. 10. Motor application.

6. Results and Discussions

6.1. Open Circuit Test for PEMFC Unit

An experiment is carried out without supplying the hydrogen gas to the cell. Four stacks of cell is used and connected in series to produce more voltages. The result of this experiment is tabulated in Table 1. At this level, the more stack is connected in series connection, the larger is the output voltage that can be produced. In order to get 3.6 V of output constantly to operate the motor application, the constant 5 V output is needed. Thus, the boost converter is used in this project.

Table 1. PEMFC stacks connected in series experiment.

No of stacks	Output Voltage (V)		
	1 st reading	2 nd reading	Average
1	0.902	0.902	0.902
2	1.801	1.799	1.800
3	2.698	2.697	2.698
4	3.596	3.597	3.597
Using boost converter	5.600	5.600	5.600

6.2. PEMFC Efficiency Test (After Fabrication)

After complete fabrication of the PEMFC by the G-Energy Technology Sdn. Bhd., testing is done to check the efficiency of the system. Using the Fuelcell Test Station, E-loader and continuous hydrogen gas supply, the voltage, output power and temperature of cells can be measured. The testing setup is done as shown in Fig. 11.

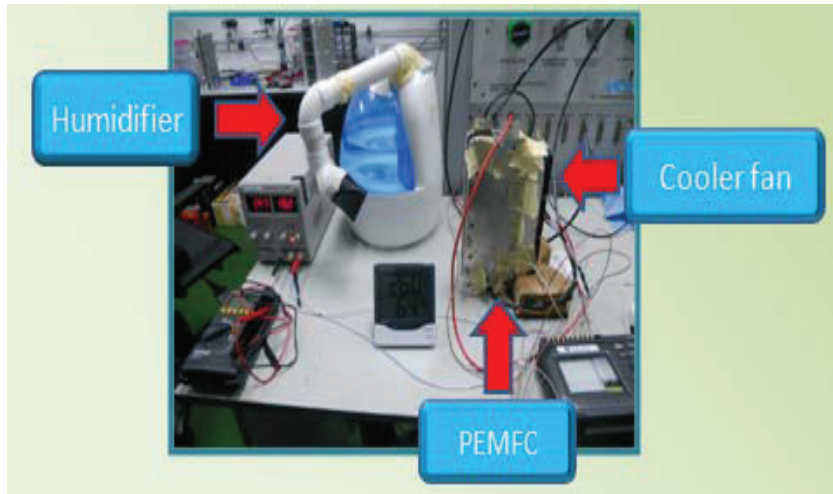

Fig. 11. Testing setup.

Fig. 12 and 13 show the test results. It is to be noted that as load current increases, the voltage drop, output power and temperature also increases. The complete results of the testing can be referred to Appendix A. Our target to get the 3.6 V, 10 W output is achieved but according to the literature reviews, the graph should be smoother than the results gained in this testing to indicate the high efficiency of the PEMFC. This is because the membrane is not fully activated since it needs to be supplied with the continuous hydrogen gas at for 40 hours to operate in optimum condition.

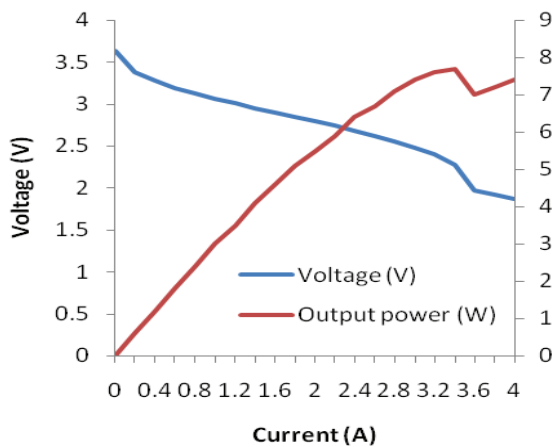

Fig. 12. Current vs. voltage, output power.

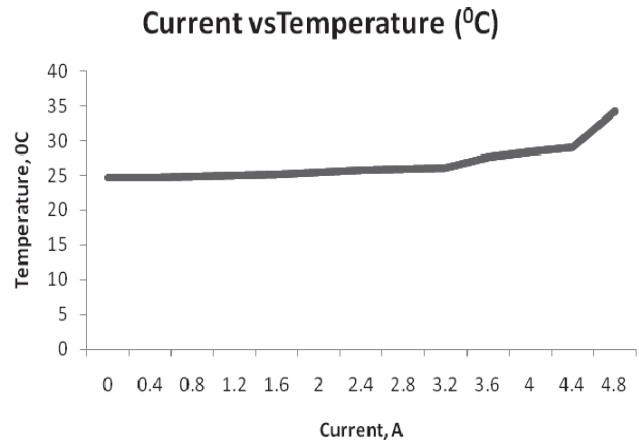

Fig. 13. Current vs. temperature.

6.3. Effect of Humidity and Air Pressure on the PEMFC Efficiency

The humidity and air pressure feed into the membrane give impact to the performance of the PEMFC. Both parameters are related to each other in water management of PEMFC. As we know, water is one of the outputs when this fuel cell generates electricity energy and the amount of water in the membrane will affect the performance of PEMFC. The quantity of the water has to manage to an optimum level in order to get the better results. This experiment is using the humidifier and DC cooling fan as the variable of the humidity and air pressure with the constant continuous 0.3 bar hydrogen gas.

Fig. 14 shows the effect of high air pressure and high humidity on the polarization curve of fuel cell by using the humidifier and high speed fan. As can be observed from the graph, the slope of the linear region of the stack voltage versus current plot remains almost constant. On the other hand, Fig. 15 shows the effect when the humidifier is not used and the graph shows the slope is not constant at the maximum output. From both results, the performance of PEMFC varies when one of this parameter change.

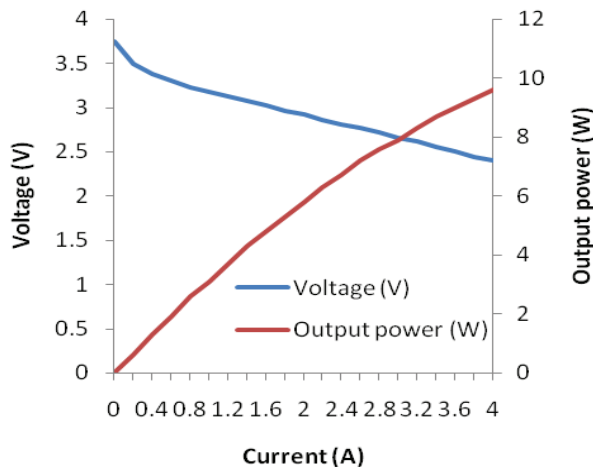

Fig. 14. High air pressure and high humidity effect.

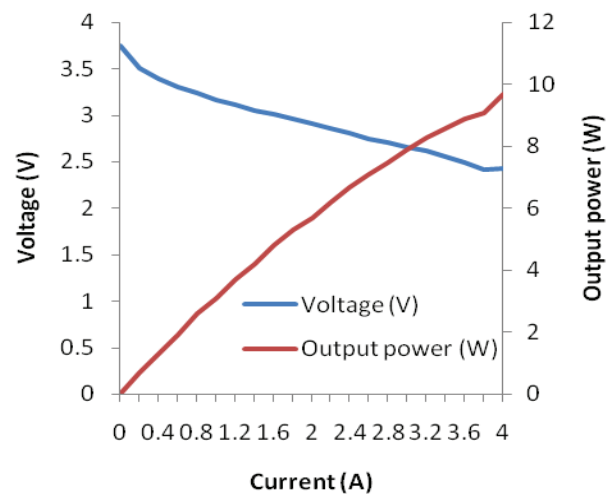

Fig. 15. High air pressure and no humidity effect.

The high air pressure increases the availability of the oxygen gas at the cathode membrane which improves the performance of the fuel cell but it also increase the rate of water removal that cause the membrane dry which increase the resistance of cell. By supplying water vapour using the humidifier, the quantity of water in membrane will increase which can avoid the membrane becoming dry. If the quantity of the water is too high, the performance of the membrane will decrease due to flooding of water, which affects the chemical reaction between the oxygen and hydrogen gas.

According to the Fig. 14, the slope of graph is not constant even though the high air pressure distribute more oxygen through the cathode membrane but a lot of water has been blown out from the membrane which make the membrane to be dried and decrease the efficiency. To counter that problem, the supply of the water vapour from the humidifier will reduce the dryness of the membrane. This can be observed in Fig. 15. From all of these results, both air pressure and humidity are related in water management to increase the performance of the PEMFC. The data of the experiment results can be referred at Appendix B.

6.3.1. Effect of High Humidity Climate on the PEMFC Efficiency

To operate the PEMFC in maximum power output the high humidity and high air pressure condition is strictly needed. Both of these parameters need to use the humidifier and high speed fan or air compressor to achieve the target power output with the highest efficiency. For the country that has high humidity in their climate, this is the huge advantage to improve the performance of the fuel cell. For example, Malaysia climate has approximately 70 % average humidity and this will reduce the dryness of the membrane which increases the performance of the PEMFC. So, the humidifier is not needed anymore as the medium to supply the humidity to the membrane.

Fig. 16 shows the effect of reducing the speed of the fan to give the mild air pressure and without using the humidifier.

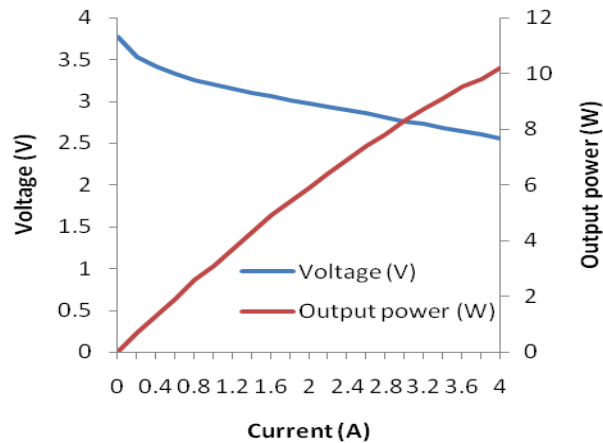

Fig. 16. Effect of the mild air pressure and no humidity.

Fig 16 shows that the maximum power output is higher than by using the high speed fan. The slope of the graph is also almost constant which indicate the good performance of the fuel cell. The mild air pressures supplies enough oxygen and reduce the water to be blown out from the membrane. Even though by not using the humidifier, the surrounding climate already has the high humidity to reduce the dryness of the PEMFC. Thus, we can reduce the auxiliary energy to run the fan and also neglect the humidifier.

7. Conclusions

There are many parameters that need to be considered to improve the performance of the fuel cell but humidity and air pressure feed into the membrane was found to have the significant effect to the performance of PEMFC. From the experimental results, the polarization curves have shown the efficiency of the fuel cell varies when both parameters change. The high humidity climate also influenced the performance of this green technology since the testing is done in Malaysia which has the highest humidity. This give advantage to operate at optimum level without using the humidifier and the auxiliary energy to run the cooling fan also can be reduced.

The complete prototype model has been fabricated for the solar hybrid car and air pump application. Both models have operated without emitting any dangerous greenhouse gas which is very clean and environmental friendly.

8. Appendices

Appendix A. High air pressure and high humidity.

Current (A)	Voltage (V)	Input power (W)	Output power (W)	Efficiency, η (%)	Temperature ($^{\circ}$ C)
0	3.630	0	0	0	24.7
0.2	3.378	1.18	0.6	50.85	24.7
0.4	3.270	2.37	1.2	50.63	24.7
0.6	3.190	3.55	1.8	50.70	24.7
0.8	3.120	4.74	2.4	50.63	24.9
1.0	3.060	5.92	3.0	50.68	24.9
1.2	3.010	7.11	3.5	49.23	25.0
1.4	2.950	8.29	4.1	49.46	25.1
1.6	2.900	9.48	4.6	48.52	25.2
1.8	2.840	10.66	5.1	47.84	25.3
2.0	2.790	11.85	5.5	46.41	25.4
2.2	2.740	13.03	5.9	45.28	25.6
2.4	2.680	14.22	6.4	45.01	25.7
2.6	2.620	15.40	6.7	43.51	25.8
2.8	2.550	16.59	7.1	42.80	25.9
3.0	2.480	17.77	7.4	41.64	25.9
3.2	2.400	18.96	7.6	40.08	26.1
3.4	2.280	20.14	7.7	38.23	26.2
3.6	1.970	21.33	7.0	32.82	27.7
3.8	1.920	22.51	7.2	31.99	28.1
4.0	1.870	23.70	7.4	31.22	28.5

Appendix B. High Air Pressure and no Humidity.

Current (A)	Voltage (V)	Input power (W)	Output power (W)	Efficiency, η (%)	Temperature ($^{\circ}$ C)
0	3.744	0	0	0	27.0
0.2	3.507	1.18	0.7	59.32	27.1
0.4	3.393	2.37	1.3	54.85	27.1
0.6	3.299	3.55	1.9	53.52	27.3
0.8	3.234	4.74	2.6	54.85	27.4
1.0	3.166	5.92	3.1	52.36	27.5
1.2	3.110	7.11	3.7	52.04	27.4
1.4	3.054	8.29	4.2	50.66	27.4
1.6	3.005	9.48	4.8	50.63	27.4
1.8	2.957	10.66	5.3	49.72	27.5
2.0	2.905	11.85	5.7	48.10	27.5
2.2	2.854	13.03	6.2	47.58	27.6
2.4	2.804	14.22	6.7	47.12	27.5
2.6	2.750	15.40	7.1	46.10	27.7
2.8	2.702	16.59	7.5	45.21	27.7
3.0	2.652	17.77	7.9	44.46	27.7
3.2	2.616	18.96	8.3	43.78	28.0
3.4	2.554	20.14	8.6	42.70	28.2
3.6	2.491	21.33	8.9	41.73	28.3
3.8	2.416	22.51	9.1	40.43	28.3
4.0	2.423	23.70	9.7	40.93	28.5

Acknowledgements

This work was supported by the G-Energy Technology Sdn. Bhd., Malaysia under research collaboration with Universiti Teknologi PETRONAS, Malaysia.

References

- [1]. M. W. Ellis, M. R. Von Spakovsky and D. J. Nelson, Fuel cell systems: Efficient, flexible energy conversion for the 21st century, *Proceedings of the IEEE, December*, Vol. 89, Issue 12, 2001, pp.1808-1818.
- [2]. J. T. Pukrushpan, A. G. Stefanopoulou, and H. Peng, Control of fuel cell breathing, *IEEE Control Systems Magazine*, Vol. 24, No. 2, April 2004, pp. 30–46.
- [3]. Catalyzed Fuel Cell Membranes, 2004, 8 June 2011 from <http://www.ion-power.com/products.html>
- [4]. Puranik, S., Keyhani, A., & Khorrami, F., Neural Network Modeling of Proton Exchange Membrane Fuel Cell, *IEEE Transactions on Energy Conversion*, Vol. 25, No. 2, June 2010, pp. 474 – 483.
- [5]. <http://www.nmsea.org/Curriculum/712/electrolysis/electrolysis.htm>
- [6]. P. Rodatz, F. Büchi, C. Onder, L. Guzzela, Operational aspect of a large PEFC stack under practical conditions, *Journal of Power Sources*, 128, 2004, pp. 208-217.
- [7]. Joseph Barbetta, PEM Fuel Cell Calculations, 2002 (<http://fuelcellhelp.com>).
- [8]. Maher A. R. Sadiq Al-Baghdadi, Haroun A. K. Shahad Al-Janabi, *Renewable Energy*, Vol. 32, 2007, pp. 1077-1101.
- [9]. Marignetti, F., Minutillo, M., Perna, A., & Jannelli, E, Assessment of Fuel Cell Performance Under Different Air Stoichiometries and Fuel Composition, *IEEE Transactions on Industrial Electronics*, June 2011, pp. 2420 - 2426.
- [10]. J. Huson, P. C. Lundberg, R. Herry, A. Bourgeau, A. Snyder, S. K. Das, Etim U. Ubong, Experimental evaluation of the effect of humidification on the performance of PEM fuel cell stack, *Electrical Insulation Conference and Electrical Manufacturing Expo*, 2007, pp. 418-422.
- [11]. Q. Yan, H. Toghiani, and H. Causey, Steady state and dynamic performance of proton exchange fuel cells (PEMFCs) under various operating conditions and load changes, *Journal of Power Sources*, 2006, Vol. 161, pp. 492–502.
- [12]. C. Ramos-Paja, R. Giral, L. Martinez-Salamero, J. Romano, A. Romero, and G. Spagnuolo, A PEM fuel-cell model featuring oxygen-excess-ratio estimation and power-electronics interaction, *IEEE Transactions on Industrial Electronics*, Vol. 57, No. 6, June 2010, pp. 1914–1924.